

Summer Assignment Incoming 1st Graders

Welcome to 1st Grade:

Research shows that over the summer break, children can lose over two months' of math learning. To help beat this Summer Slide, scholars have been given a Math Summer Assignment. The completed assignment is due on August 14, 2026 and will be worth a Quiz Grade.

We wish you a great Summer Break!

Sincerely,

Archimedean Academy
Math Team

Name: _____

Date: _____

Worksheet

Number Words

(1-20)

1. Write the numbers in words.

3	<hr/> <hr/> <hr/>
18	<hr/> <hr/> <hr/>
12	<hr/> <hr/> <hr/>
7	<hr/> <hr/> <hr/>
15	<hr/> <hr/> <hr/>

5	<hr/> <hr/> <hr/>
13	<hr/> <hr/> <hr/>
8	<hr/> <hr/> <hr/>
11	<hr/> <hr/> <hr/>
4	<hr/> <hr/> <hr/>

2. Write the word names as numbers.

one	<input type="text"/>
ten	<input type="text"/>
fourteen	<input type="text"/>
nine	<input type="text"/>
seventeen	<input type="text"/>

six	<input type="text"/>
two	<input type="text"/>
twenty	<input type="text"/>
sixteen	<input type="text"/>
nineteen	<input type="text"/>

Word Problem Solving. Read the story and answer the question.

Write the problem out in the box or on the lines. The first one is done for you.

1. Tom has 2 worms for fishing. 1 worm got out of the can. How many worms are left?



$$2 - 1 = \underline{\quad 1 \quad}$$

2. Jane had 4 dolls. 2 broke. How many does she have left?



$$\begin{array}{r} 4 \\ - 2 \\ \hline \end{array}$$

3. 5 lights were on in the house. 3 lights were turned off. How many are still on?

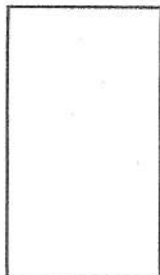

4. 6 stars were shining. A cloud covered 4 of them. How many stars are still shining?



$$\underline{\quad} - \underline{\quad} = \underline{\quad}$$

5. The dog had 6 bones. He did not eat any of them. How many bones does the dog have?



$$\underline{\quad} - \underline{\quad} = \underline{\quad}$$

6. Debra put 5 pennies in her bank. She took out 2 to buy a gum ball. How many pennies are in the bank now?



$$\underline{\quad} - \underline{\quad} = \underline{\quad}$$

7. David had 6 candles on his cake. He blew out 3. How many candles are still burning on David's birthday cake?





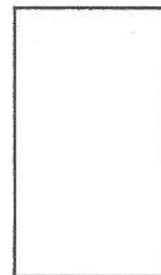
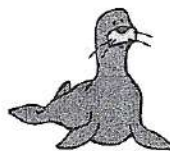



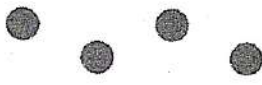

8. 3 seals were playing by the pool. 2 seals jumped into the pool. How many seals are left playing by the pool?

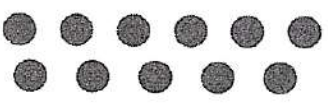

Number Words: Mixed Practice

Count the dots then draw a line from the numeral answer that tells how many dots to the matching number word. The first one is done for you.

<p>1. </p> <p>4  eight 8 one 5 four 1 five</p>	<p>2.</p> <p>one 0 eleven 10 zero 1 ten 11</p>	<p>3. </p> <p>nine 8 eight 11 six 9 eleven 6</p>
<p>4. </p> <p>7 ten 10 seven 1 one 5 five</p>	<p>5. </p> <p>11 eight 4 eleven 2 four 8 two</p>	<p>6. </p> <p>4 seven 5 six 7 five 6 four</p>
<p>7. </p> <p>11 seven 6 six 1 eleven 7 one</p>	<p>8. </p> <p>5 twelve 12 five 4 six 6 four</p>	<p>9. </p> <p>3 twelve 2 three 10 ten 12 two</p>



Write the numeral for each of the number words below.
 The first one is done for you.

- seventeen 17
- twenty _____
- fourteen _____
- sixteen _____

- eighteen _____
- fifteen _____
- nineteen _____
- thirteen _____

Name _____

Addition 7—12: Matching Equations and Answers

Draw a line to the answer that solves each problem. The first one is done for you.

<p>1.</p> $6 + 2 = 11$ $7 + 4 = 10$ $8 + 1 = 12$ $1 + 6 = 8$ $5 + 5 = 7$ $4 + 8 = 9$	<p>2.</p> $5 + 2 = 10$ $6 + 3 = 8$ $2 + 9 = 12$ $3 + 9 = 11$ $4 + 4 = 9$ $8 + 2 = 7$	<p>3.</p> $8 + 0 = 11$ $4 + 6 = 9$ $1 + 11 = 7$ $0 + 9 = 12$ $6 + 1 = 8$ $9 + 2 = 10$
<p>4.</p> $1 + 10 = 12$ $8 + 4 = 8$ $7 + 2 = 7$ $6 + 2 = 11$ $0 + 10 = 10$ $4 + 3 = 9$	<p>5.</p> $11 + 1 = 9$ $9 + 0 = 7$ $6 + 5 = 12$ $5 + 3 = 10$ $1 + 6 = 11$ $2 + 8 = 8$	<p>6.</p> $7 + 3 = 8$ $3 + 8 = 9$ $1 + 7 = 10$ $12 + 0 = 11$ $0 + 7 = 12$ $5 + 4 = 7$
<p>7.</p> $5 + 6 = 9$ $2 + 5 = 8$ $8 + 2 = 11$ $10 + 2 = 7$ $0 + 8 = 12$ $3 + 6 = 10$	<p>8.</p> $1 + 9 = 10$ $2 + 6 = 8$ $6 + 6 = 12$ $2 + 7 = 9$ $4 + 7 = 11$ $3 + 4 = 7$	<p>9.</p> $0 + 12 = 8$ $2 + 8 = 10$ $3 + 5 = 9$ $11 + 0 = 12$ $4 + 3 = 11$ $3 + 6 = 7$
<p>10.</p> $2 + 10 = 10$ $3 + 7 = 12$ $7 + 1 = 11$ $2 + 9 = 8$ $3 + 6 = 9$	<p>11.</p> $7 + 5 = 11$ $9 + 1 = 12$ $10 + 1 = 10$ $3 + 5 = 8$ $6 + 3 = 9$	<p>12.</p> $7 + 2 = 8$ $5 + 7 = 10$ $6 + 5 = 11$ $10 + 0 = 12$ $2 + 6 = 9$

Addition 7—12: Word Problem Solving

Read the stories and write a number sentence or problem to tell the answer.
The first one is done for you.

<p>1. Mother hen has 4 chicks. Mother pig has 5 piglets. How many babies do they have in all?</p> $\underline{4} + \underline{5} = \underline{9}$	<p>2. Jim has 8 toy cars. He got 2 more for his birthday. How many cars does he have?</p> $\underline{\quad} + \underline{\quad} = \underline{\quad}$
<p>3. Sue bought 3 candy bars. Her mother gave her 8 more for her friends. How many does she have?</p> $\underline{\quad} + \underline{\quad} = \underline{\quad}$	<p>4. Amanda read 1 book today and 7 last week. How many books has she read?</p> <div style="border: 1px solid black; width: 100px; height: 100px; margin-left: auto;"></div>
<p>5. Farmer Fisher had 6 brown and 6 black cows. How many cows did he have in all?</p> <div style="border: 1px solid black; width: 100px; height: 100px; margin-left: auto;"></div>	<p>6. Mark has 5 sisters and 2 brothers. How many brothers and sisters does Mark have altogether?</p> <div style="border: 1px solid black; width: 100px; height: 100px; margin-left: auto;"></div>

Keeping Up

Write the numeral that comes between. The first one is done for you.

24 25 26

48 _____ 50

77 _____ 79

14 _____ 16

21 _____ 23

19 _____ 21

66 _____ 68

50 _____ 52

39 _____ 41

0 _____ 2

98 _____ 100

81 _____ 83



59 _____ 61

10 _____ 12

33 _____ 35

Subtraction 7—12: Problem Solving

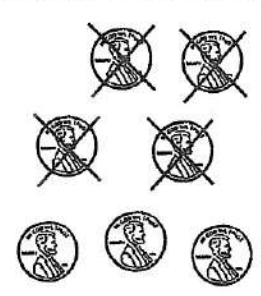
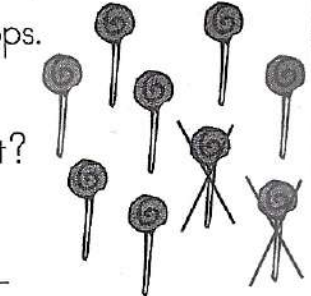
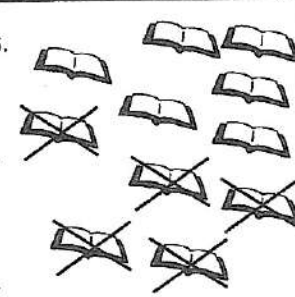
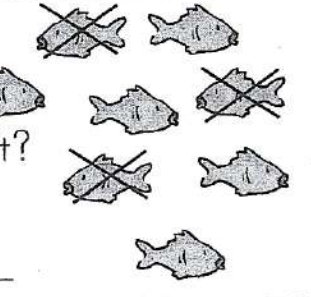
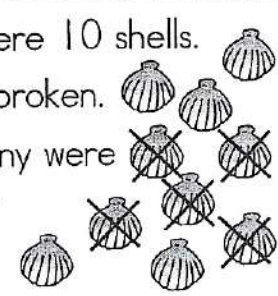
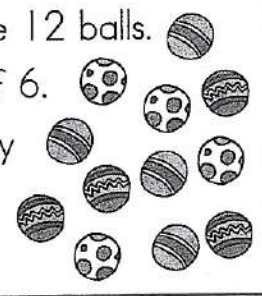
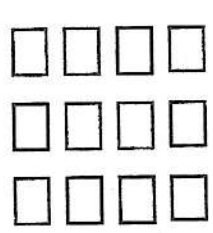
Count back to help you find the difference. The first one is done for you.

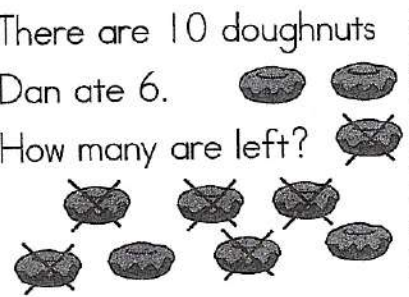
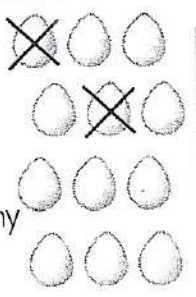
<p>1. There are 7 pennies. 4 roll away. How many are left?</p> <p>$7 - 4 = \underline{3}$</p> 	<p>2. There are 9 lollipops. 2 were eaten. How many are left?</p> <p>$9 - 2 = \underline{\quad}$</p> 
<p>3. Mike has 11 books. He read 5 books. How many does he have left to read?</p> <p>$11 - \underline{\quad} = \underline{\quad}$</p> 	<p>4. There are 8 fish. 3 swam away. How many are left?</p> <p>$8 - \underline{\quad} = \underline{\quad}$</p> 
<p>5. There were 10 shells. 5 were broken. How many were broken?</p> <p>$\begin{array}{r} 10 \\ - 5 \\ \hline \end{array}$</p> 	<p>6. There are 12 balls. Cross off 6. How many are left?</p> <p>$\begin{array}{r} 12 \\ - 6 \\ \hline \end{array}$</p> 
<p>7. There are 12 boxes. Cross off 4. How many are not crossed off?</p> <p>$12 - \square = \underline{\quad}$</p> 	<p>8. There are 11 cups. 7 were used for hot chocolate. How many were not used?</p> <p>$\begin{array}{r} 11 \\ - \square \\ \hline \end{array}$</p> 
<p>9. There are 10 doughnuts. Dan ate 6. How many are left?</p> <p>$\begin{array}{r} 10 \\ - \square \\ \hline \end{array}$</p> 	<p>10. There are 12 eggs. Mom used 2 for the cake. How many eggs are left?</p> <p>\square</p> 

Subtraction 7—12: Matching Equations and Answers

Draw a line to the correct answer. The first one is done for you.

1. $9 - 1 = 7$ $10 - 3 = 8$ $11 - 9 = 0$ $7 - 4 = 3$ $8 - 7 = 2$ $12 - 12 = 1$	2. $10 - 0 = 0$ $7 - 7 = 5$ $11 - 8 = 10$ $9 - 3 = 8$ $10 - 5 = 6$ $12 - 4 = 3$	3. $11 - 4 = 3$ $8 - 4 = 10$ $12 - 9 = 7$ $7 - 6 = 1$ $11 - 1 = 5$ $9 - 4 = 4$
4. $12 - 8 = 2$ $12 - 6 = 3$ $10 - 8 = 4$ $11 - 11 = 0$ $10 - 7 = 5$ $8 - 3 = 6$	5. $9 - 9 = 7$ $11 - 6 = 4$ $7 - 0 = 0$ $12 - 10 = 1$ $9 - 8 = 2$ $7 - 3 = 5$	6. $10 - 9 = 2$ $8 - 6 = 1$ $12 - 0 = 4$ $11 - 7 = 12$ $12 - 11 = 4$ $9 - 5 = 1$
7. $12 - 1 = 9$ $11 - 2 = 5$ $8 - 1 = 1$ $7 - 6 = 11$ $12 - 7 = 4$ $10 - 6 = 7$	8. $9 - 6 = 3$ $10 - 2 = 8$ $11 - 0 = 11$ $12 - 2 = 10$ $11 - 10 = 1$ $8 - 5 = 3$	9. $7 - 2 = 8$ $10 - 10 = 5$ $12 - 3 = 0$ $9 - 7 = 9$ $11 - 1 = 2$ $8 - 0 = 10$
10. $7 - 5 = 8$ $9 - 5 = 2$ $8 - 0 = 9$ $10 - 1 = 4$ $11 - 3 = 8$	11. $8 - 2 = 10$ $12 - 2 = 5$ $11 - 6 = 6$ $12 - 4 = 0$ $8 - 8 = 8$	12. $10 - 4 = 6$ $10 - 6 = 3$ $8 - 5 = 9$ $9 - 0 = 5$ $9 - 4 = 4$

Subtraction 7—12: Comparison

Complete the problems then circle those which equal the numeral in the box.
The first two are done for you.

<p>1.</p> <div style="border: 1px solid black; width: 40px; height: 40px; margin: 0 auto; display: flex; align-items: center; justify-content: center; font-size: 24px;">8</div> <div style="border: 1px dashed black; border-radius: 50%; padding: 5px; margin: 5px auto; display: flex; align-items: center; justify-content: center;"> $10 - 2 = 8$ </div> $10 - 1 = 9$ $11 - 3 =$ $11 - 0 =$ $12 - 4 =$ $8 - 0 =$	<p>2.</p> <div style="border: 1px solid black; width: 40px; height: 40px; margin: 0 auto; display: flex; align-items: center; justify-content: center; font-size: 24px;">9</div> $7 - 2 =$ $12 - 3 =$ $10 - 1 =$ $11 - 2 =$ $10 - 8 =$ $9 - 0 =$	<p>3.</p> <div style="border: 1px solid black; width: 40px; height: 40px; margin: 0 auto; display: flex; align-items: center; justify-content: center; font-size: 24px;">7</div> $8 - 1 =$ $9 - 2 =$ $10 - 5 =$ $7 - 4 =$ $11 - 4 =$ $12 - 5 =$
<p>4.</p> <div style="border: 1px solid black; width: 40px; height: 40px; margin: 0 auto; display: flex; align-items: center; justify-content: center; font-size: 24px;">12</div> $12 - 1 =$ $12 - 6 =$ $11 - 2 =$ $12 - 0 =$	<p>5.</p> <div style="border: 1px solid black; width: 40px; height: 40px; margin: 0 auto; display: flex; align-items: center; justify-content: center; font-size: 24px;">10</div> $11 - 1 =$ $10 - 10 =$ $10 - 0 =$ $12 - 2 =$	<p>6.</p> <div style="border: 1px solid black; width: 40px; height: 40px; margin: 0 auto; display: flex; align-items: center; justify-content: center; font-size: 24px;">11</div> $11 - 6 =$ $12 - 1 =$ $11 - 0 =$ $12 - 9 =$
<p>7.</p> <div style="border: 1px solid black; width: 40px; height: 40px; margin: 0 auto; display: flex; align-items: center; justify-content: center; font-size: 24px;">6</div> $8 - 2 =$ $9 - 5 =$ $10 - 4 =$ $12 - 7 =$ $11 - 5 =$ $12 - 10 =$	<p>8.</p> <div style="border: 1px solid black; width: 40px; height: 40px; margin: 0 auto; display: flex; align-items: center; justify-content: center; font-size: 24px;">4</div> $2 - 2 =$ $9 - 5 =$ $11 - 7 =$ $8 - 2 =$ $10 - 6 =$ $12 - 8 =$	<p>9.</p> <div style="border: 1px solid black; width: 40px; height: 40px; margin: 0 auto; display: flex; align-items: center; justify-content: center; font-size: 24px;">5</div> $11 - 6 =$ $9 - 4 =$ $7 - 2 =$ $10 - 3 =$ $8 - 3 =$ $12 - 7 =$

Keeping Up. Write the numeral. The first one is done for you.

twelve 12

nine _____

eleven _____

one _____

four _____





seven _____

eight _____

five _____

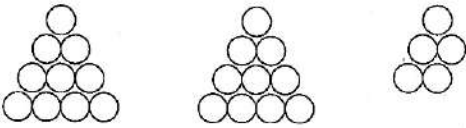
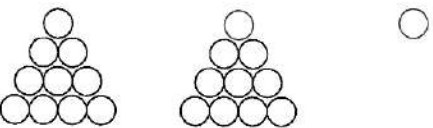
Place Value: Tens and Ones

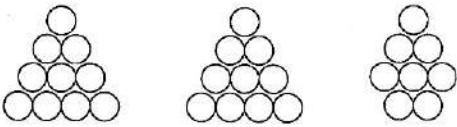
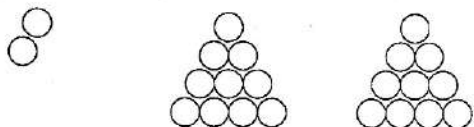
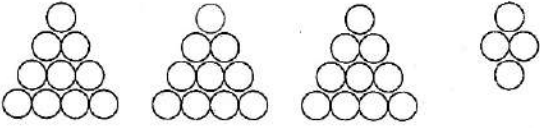
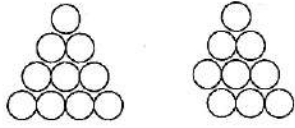
Write how many sets of ten and how many ones are in each problem.
The first one is done for you.

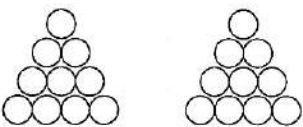
<p>1.</p>  <p>_____ _____ ten _____ 3 _____ ones</p>	<p>2.</p>  <p>_____ tens _____ ones</p>
<p>3.</p>  <p>_____ tens _____ ones</p>	<p>4.</p>  <p>_____ ten _____ ones</p>
<p>5.</p>  <p>_____ tens _____ ones</p>	<p>6.</p>  <p>_____ tens _____ ones</p>
<p>7.</p>  <p>_____ tens _____ ones</p>	<p>8.</p>  <p>_____ ten _____ ones</p>
<p>9.</p>  <p>_____ ten _____ ones</p>	<p>10.</p>  <p>_____ tens _____ ones</p>

Name _____

Place Value: Tens and Ones. Fill in the blanks with the correct number of tens and ones. The first one is done for you.

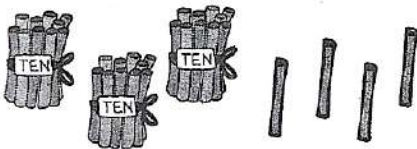
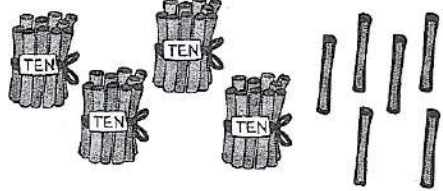
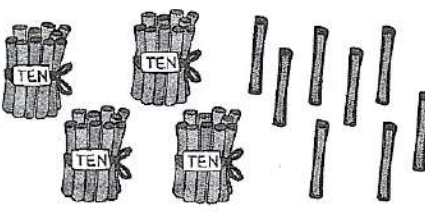
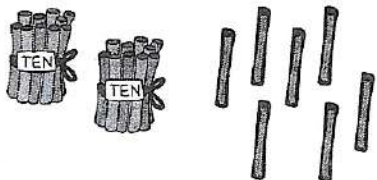
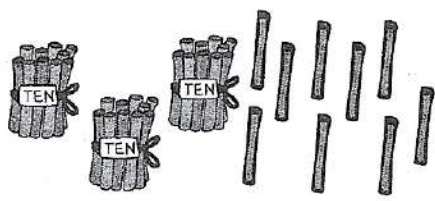
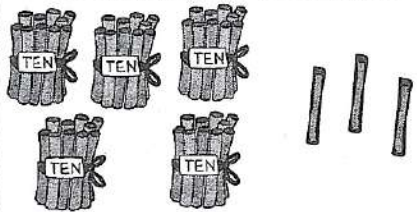

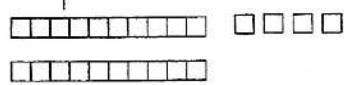
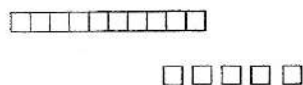
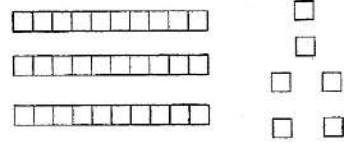
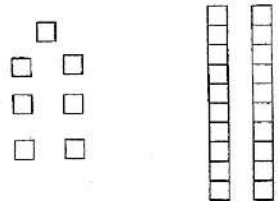
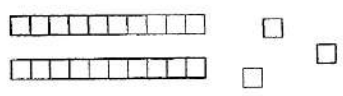
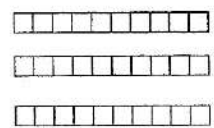

<p>1. 3 tens 4 ones</p> 	<p>2. _____ tens _____ ones</p> 	<p>3. _____ tens _____ ones</p> 
<p>4. _____ tens _____ ones</p> 	<p>5. _____ tens _____ ones</p> 	<p>6. _____ tens _____ ones</p> 

Fill in the blanks with the correct number of tens, ones and the total of both together.

<p>Example:</p>  <p>_____ tens _____ ones =</p> <p style="text-align: center; margin-left: 100px;">24</p>	<p>7.</p>  <p>_____ ten _____ ones =</p> <p style="text-align: center;">_____</p>	<p>8.</p>  <p>_____ tens _____ ones =</p> <p style="text-align: center;">_____</p>
<p>9.</p>  <p>_____ tens _____ ones =</p> <p style="text-align: center;">_____</p>	<p>10.</p>  <p>_____ tens _____ ones =</p> <p style="text-align: center;">_____</p>	<p>11.</p>  <p>_____ tens _____ ones =</p> <p style="text-align: center;">_____</p>

Place Value: Tens and Ones

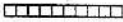
Draw pictures to show how many tens and how many ones are in each problem.

Use   ,  / or   . The first one is done for you.

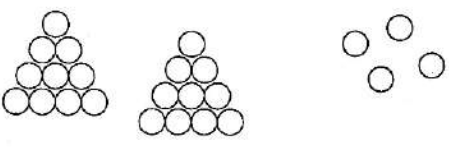
<p>1.</p> <p>2 tens 4 ones</p> 	<p>2.</p> <p>1 tens 6 ones</p>
<p>3.</p> <p>3 tens 5 ones</p>	<p>4.</p> <p>19</p>

Be sure to read carefully and split each numeral into the correct amount of tens and ones. The first one is done for you.

5. 46 is 4 tens 6 ones 10. 2 tens, 3 ones is _____
6. 23 is _____ tens _____ ones 11. 4 tens, 1 ones is _____
7. 16 is _____ ten _____ ones 12. 8 tens, 4 ones is _____
8. 51 is _____ tens _____ one 13. 2 ones, 5 tens is _____
9. 83 is _____ ones _____ tens 14. 7 tens, 7 ones is _____



Circle the one that is greater. The first one is done for you.

15. 2 tens, 7 ones 17. 6 tens, 9 ones 19. 9 tens, 9 ones
 (7 tens, 2 ones) 9 tens, 6 ones 9 tens, 8 ones
16. 4 tens, 8 ones 18. 5 tens, 3 ones 20. 4 tens, 6 ones
 8 tens, 4 ones 3 tens, 5 ones 4 tens, 2 ones

Name _____

Mixed Practice Review: Facts 0 — 18

Fill in the blanks with the sum or difference. The first one is done for you.

1. $0 + 13 = 13$ $10 - 4 =$ _____ $2 + 11 =$ _____ $9 + 6 =$ _____ $18 - 9 =$ _____ $7 + 8 =$ _____	2. $11 + 5 =$ _____ $10 - 5 =$ _____ $12 - 3 =$ _____ $8 + 9 =$ _____ $2 + 10 =$ _____ $0 + 11 =$ _____	3. $3 + 0 =$ _____ $16 + 2 =$ _____ $7 + 3 =$ _____ $9 - 8 =$ _____ $8 - 1 =$ _____ $17 - 10 =$ _____
4. $11 - 6 =$ _____ $12 - 5 =$ _____ $15 + 3 =$ _____ $18 + 0 =$ _____ $11 - 9 =$ _____ $7 + 5 =$ _____	5. $0 - 0 =$ _____ $0 + 9 =$ _____ $10 + 0 =$ _____ $10 - 0 =$ _____ $17 - 0 =$ _____ $9 + 0 =$ _____	6. $8 + 10 =$ _____ $11 - 11 =$ _____ $9 + 8 =$ _____ $8 - 1 =$ _____ $11 - 1 =$ _____ $3 + 2 =$ _____
7. $10 + 3 =$ _____ $5 + 13 =$ _____ $7 + 5 =$ _____ $6 + 6 =$ _____ $17 - 5 =$ _____ $12 - 6 =$ _____	8. $17 - 15 =$ _____ $10 + 8 =$ _____ $11 - 0 =$ _____ $9 + 1 =$ _____ $11 - 4 =$ _____ $6 + 5 =$ _____	9. $13 - 4 =$ _____ $10 + 2 =$ _____ $0 + 12 =$ _____ $18 - 11 =$ _____ $3 + 0 =$ _____ $8 - 8 =$ _____

Keeping Up. Follow the instructions below.

first



1. Color the third and tenth cars blue.
2. Color the ninth and first cars green.
3. Color the fifth and seventh cars brown.
4. Color the second and fourth cars red.
5. Color the sixth and eighth cars black.